

Description

Low impedance
 Low ESR
 Wide frequency range

Applications

Power supplies
 Hi-End electronics
 Industrial electronics

Electrical characteristics



Operating temperature: $-25^{\circ}\text{C} \div 70^{\circ}\text{C}$
 Rated voltage: 385Vdc \div 500Vdc
 Rated capacitance: $47\mu\text{F} \div 800\mu\text{F}$
 Capacitance tolerance (pri 100Hz, 20°C): $-10\%+30\%$
 Dissipation factor (pri 100Hz, 20°C): $0,15 \div 0,25$
 Leakage current (after 5 minutes application of rated voltage): $I = 0,005.C.U$
 I - current [μA]
 C - rated capacitance [μF]
 U - rated voltage [V]

The aluminum case capacitors are supplied with PVC sleeve insulation and a safety vent located on end-deck.

Load life:

Load life is 1000 Hrs (at maximum operating temperature, at rated voltage and AC current load as per Table 1).
 After 1000 Hrs of the above application of rated voltage and current load, capacitors must meet the following characteristics requirements:
 Capacitance change \leq $\pm 15\%$ of initial value
 Tan $\delta \leq 150\%$ of initial value
 Leakage current \leq initial value

AC Load:

The maximum AC load at maximum operating temperature (70°C) is given in Table 1. The AC load can be increased at lower operating temperatures by coefficient as per Table 2, with capacitor life expectancy unaffected.

Coefficient for permissible Iac increase	2,3	2,0	1,7	1,53	1,3	1,15	1,0
Operating temperature	$\leq 40^{\circ}\text{C}$	45°C	50°C	55°C	60°C	65°C	70°C

02
 table

01 table

Type Number	Rated Capacitance C_N [μ F]	Rated Voltage U_N [V]	Dimensions [D x L mm]	max. $\tan\delta$ at 100Hz, 20°C	Iac [mA]	Drawing Number
TE 030	47	385	22 x 42	0,15	250	1
TE 030	100	385	22 x 42	0,15	450	1
TE 030	150	385	25 x 42	0,15	540	1
TE 030	220	385	30 x 50	0,15	650	1
TE 030	330	385	30 x 50	0,15	800	1
TC 309	350	385	35 x 50	0,18	830	2
TC 309	550	385	35 x 68	0,18	1000	2
TC 309	800	385	35 x 88	0,18	1200	2
TE 050	47	500	22 x 42	0,18	160	1
TE 050	68	500	22 x 42	0,18	210	1
TE 050	100	500	25 x 42	0,18	300	1
TE 050	200	500	30 x 50	0,18	500	1
TC 509	250	500	35 x 68	0,25	600	2
TC 509	250	500	35 x 88	0,25	650	2
TC 509	500	500	35 x 88	0,25	1000	2
TC 529	32+32	500	35 x 50	0,20	150+150	3
TC 529	50+50	500	35 x 50	0,20	200+200	3
TC 529	100+100	500	35 x 68	0,20	410+410	3
TC549	40+20+20+20	500	40 x 50	0,20	160+3x80	4

Note: Capacitors up to and including diameter D=20 mm are supplied with snap-in type connection; capacitors with diameter 35 and 40 mm have connection by means of solder tags.

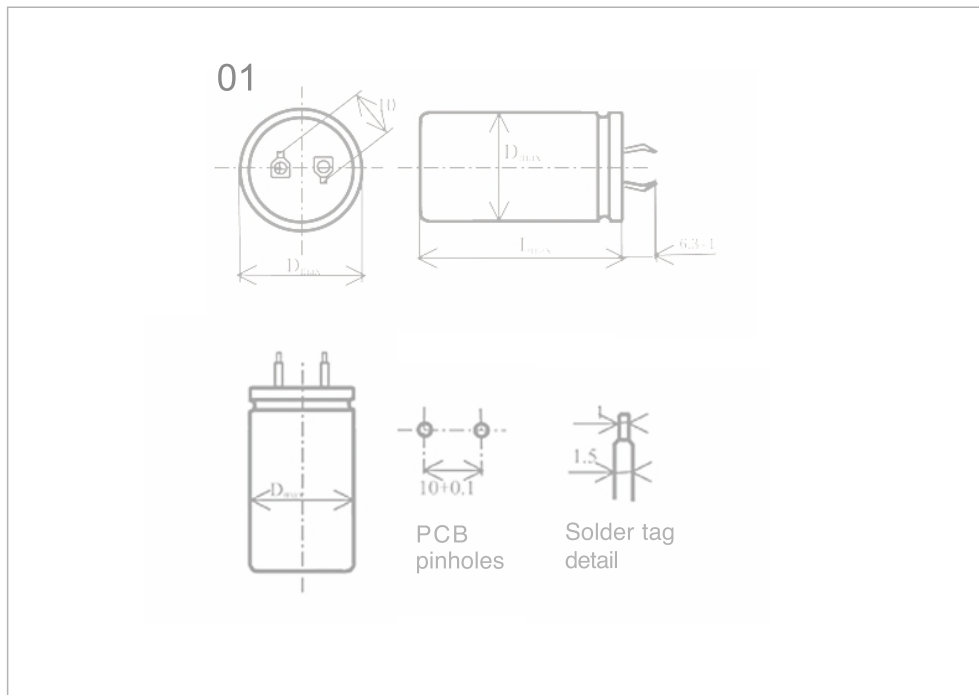

02

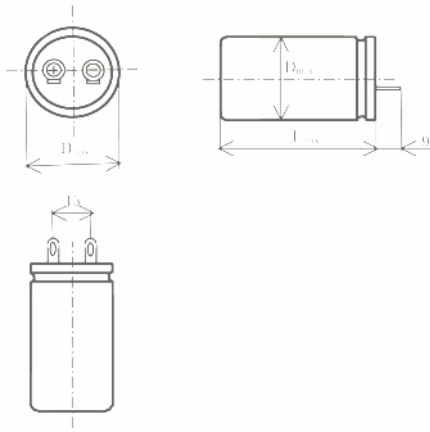

04

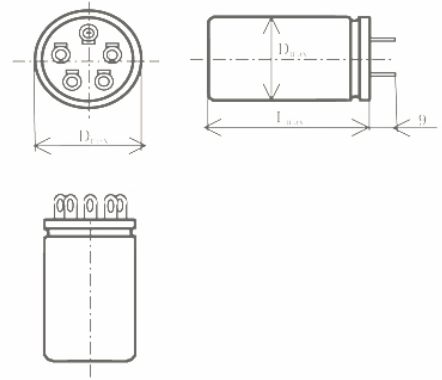

03

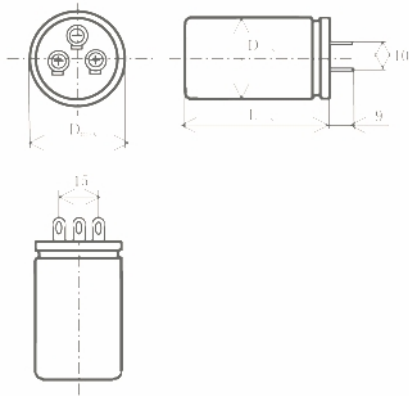

05

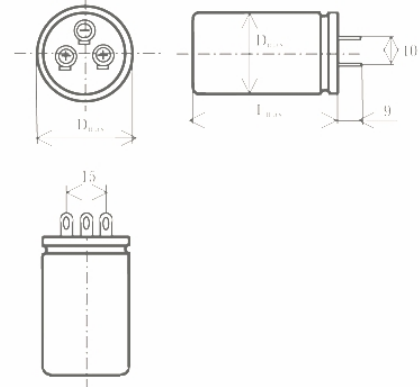

Dissipation factor vs. frequency

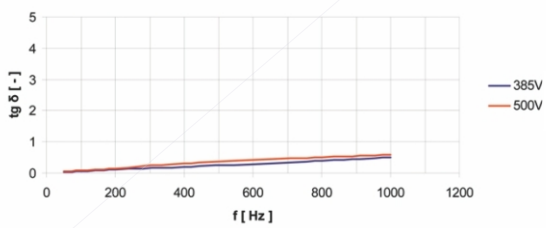

Impedance vs. frequency

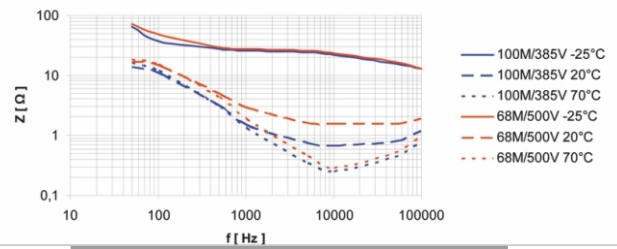

Dissipation factor vs. temperature

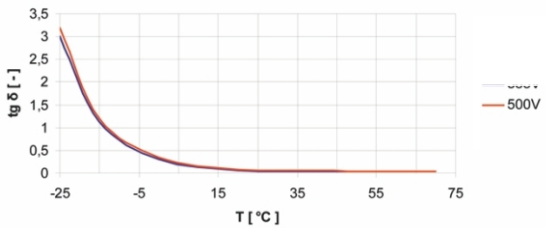

Impedance vs. frequency

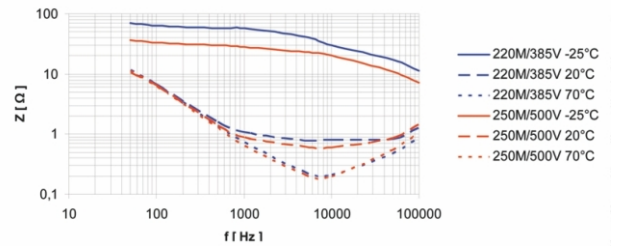

Capacitance factor vs. temperature

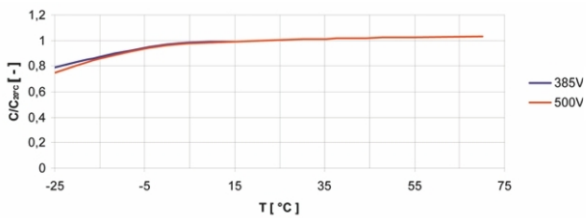

Impedance vs. frequency

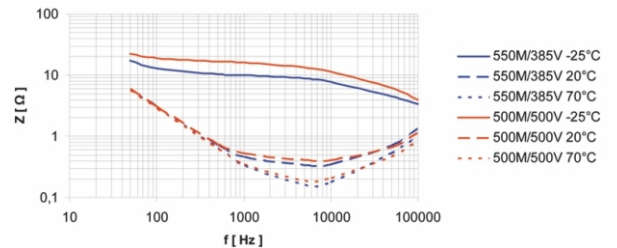

Capacitance factor vs. frequency

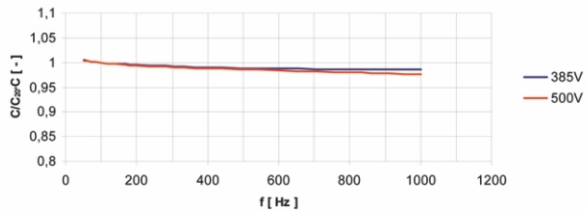

Impedance vs. frequency

